

Rising Plug Valves

SRPV Series

Features

- Non-rotating stem tip
- Straight-through orifice for maximum flow
- Stem dust seal protects threads from external contamination
- Replaceable seals, seat and stem tip
- Panel mounting option
- Gauge port option

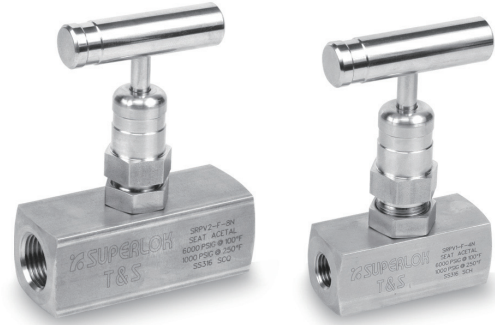

Specifications

Pressure rating	6000psig (413bar) @100°F(37°C)
Temperature rating	-20 to 400°F (-28 to 204 °C)
Body material	316 stainless steel
Orifice	4.8mm, 6.4mm

Flow Data at 100 °F (37 °C)

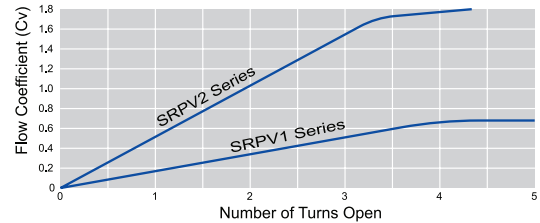

Testing

Each Valve is tested with nitrogen at 1000psig(69bar) to maximum allowable leak rate of 0.1 SCCM.

Technical Data

Pressure - Temperature Ratings

Body Material	316 Stainless Steel	
	Acetal	PEEK
Seat Material	Working Pressure, psig (bar)	
Temperature Rating °F (°C)	Working Pressure, psig (bar)	
-20 to 100 (-28 to 37)	6000 (413)	6000 (413)
200 (93)	2650 (182)	3000 (206)
250 (121)	1000 (68.9)	1600 (110)
300 (148)	-	1300 (89.5)
350 (176)	-	1200 (82.6)
400 (204)	-	1000 (68.9)

O-ring Material	Temperature Rating °F (°C)
VITON	-20 to 400 (-28 to 204)
Buna-N	-20 to 250 (-28 to 121)
Ethylene Propylene	-20 to 250 (-28 to 121)
Kalrez	-20 to 400 (-28 to 204)

• Viton O-ring is standard.

Materials of Construction

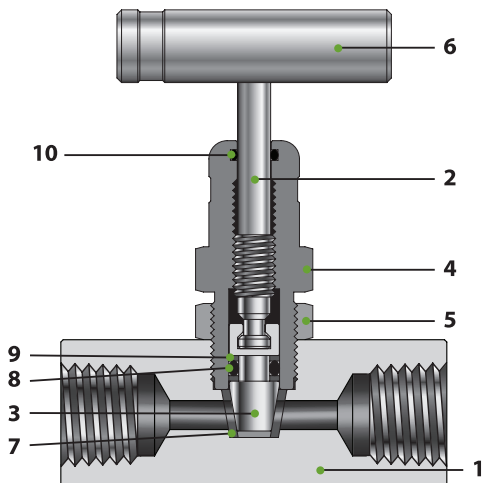

No.	Component	Material Grade / ASTM Specification
		Stainless Steel
*1	Body	A276-316
2	Stem	A276-316
*3	Stem tip	A276-316
*4	Bonnet	A276-316
5	Lock Nut	A276-316
6	Handle	A276-316
*7	Seat	Acetal
*8	Stem Seal	Viton
*9	Back-up Ring	PTFE
10	Dust Seal	Viton

• Wetted components are marked **

Table of Dimensions

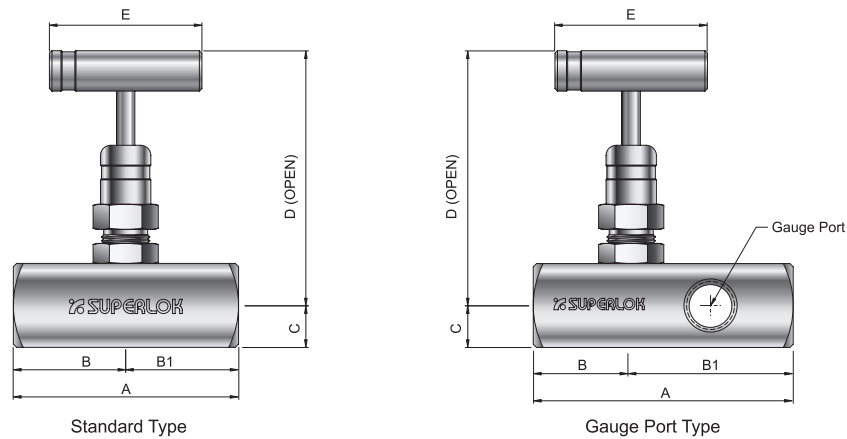

Part Number	Orifice	Cv	End Connections		Dimensions						
			Port 1	Port 2	A	B	B1	C	D	E	
SRPV1	F4N	4.8	0.63	1/4" Female NPT		62.0	31.0	31.0	12.7	96.3	60.0
	M4N-F4N			1/4" Male NPT	1/4" Female NPT	76.2	45.2				
	M8N-F4N			1/2" Male NPT	1/4" Female NPT	81.1	50.1				
SRPV1-G4N	F4N	4.8	0.63	1/4" Female NPT		78.0	31.0	47.0	12.7	96.3	60.0
	M8N-F4N			1/2" Male NPT	1/4" Female NPT	97.1	50.1				
SRPV2	F8N	6.4	1.80	1/2" Female NPT		84.0	42.0	42.0	16.0	96.9	60.0
	M8N-F8N			1/2" Male NPT	1/2" Female NPT	103.1	61.1				
	M12N-F8N			3/4" Male NPT	1/2" Female NPT	103.1	61.1				
SRPV2-G8N	F8N	6.4	1.80	1/2" Female NPT		107.4	42.0	65.4	16.0	96.9	60.0
	M8N-F8N			1/2" Male NPT	1/2" Female NPT	126.5	61.1				
	M12N-F8N			3/4" Male NPT	1/2" Female NPT	126.5	61.1				

• All dimensions in millimeters unless specified as "inch". Dimension are for reference only, subject to change
 • ISO Tapered Threads are available upon request

Ordering Information

Example : SRPV1 - F4N - PE - EP - P - SS

1 2 3 4 5 6 7

1. Valve Series

SRPV1 : Without gauge port
 SRPV1-G4N : Gauge port 1/4" NPT
 SRPV2 : Without gauge port
 SRPV2-G8N : Gauge port 1/2" NPT

2. Port Type

M : Male Pipe Thread
 F : Female Pipe Thread

3. Port Size

Pipe Thread Designation

Size (inch)	1/4	1/2	3/4
Screwed NPT	4N	8N	12N
Screwed BSPT	4R	8R	12R

4. Seat Material

Blank : Acetal (Standard)
 PE : PEEK

5. O-ring Material

Blank : Viton (Standard)
 N : Buna N
 EP : Ethylene propylene (EPDM)
 KAL : Kalrez

6. Panel Mounting

Blank : Without Panel Mounting (Standard)
 P : Panel Mounting Type

7. Body Material

SS : 316 Stainless Steel